

# DRAWERS & SUSPENDED CABINET WITH MOUNTING KIT

(for RTW, PedSys & Easy-Lift 4-post)

Item Numbers 8601, 8606, 8608, 8611, 8614, 8616, 8618, 8841, 8843, 8845, 8847, 8849, 8851

| PARTS AND HARDWARE                             | QUANTITY |
|------------------------------------------------|----------|
| Drawer                                         | 1        |
| Drawer or Cabinet Chassis                      | 1        |
| Lock Mechanism (if ordered)                    | 1        |
| Keys                                           | 2        |
| Adjustable Drawer Mounting Kit (2 pieces each) | 1        |
| Bolts                                          | 6        |
| Keyp Nuts                                      | 6        |
| Washers                                        | 6        |
| <b>Other Items Needed (not included)</b>       |          |
| Phillips head screwdriver                      |          |
| Open end wrench                                |          |

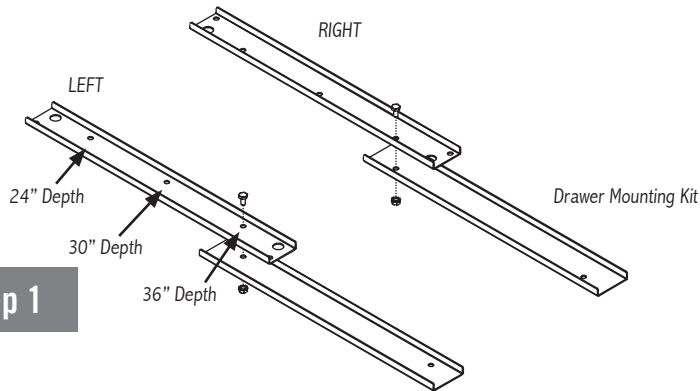

**Step 1**

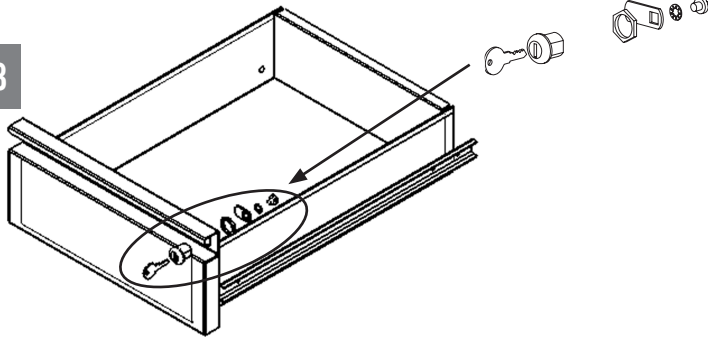

**Steps 2-3**

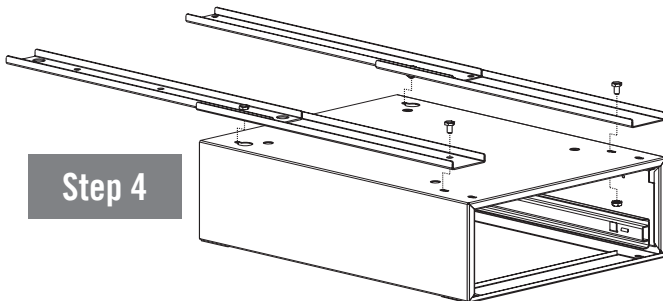

**Step 4**

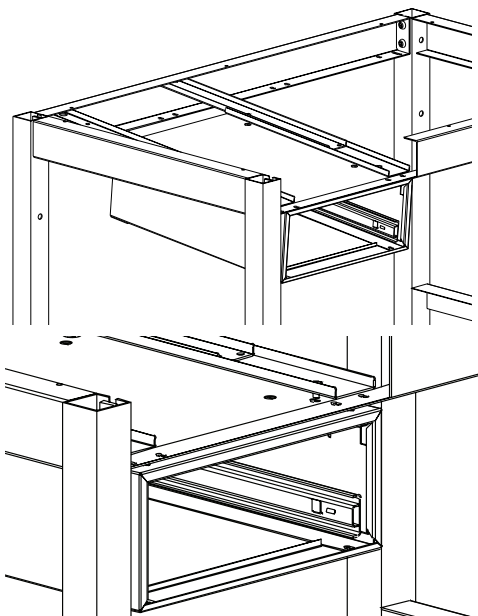

**Step 5-7**

•**Note: Drawer locks are sold separately.**

1. Assemble Drawer Mounting Kit as shown by inserting bolts through top of bracket and securing loosely with washer and nut. Align bracket based on depth of your workstation (24", 30" or 36"). Large holes on the bracket face inward.
2. If installing cabinet, skip to Step 3. If installing Drawer: Remove the drawer from the chassis by extending drawer and pushing the black tabs on the drawer slides up on the right and down on the left. Pull the drawer forward.
3. If locks were not ordered, skip to step 4. Using a screw driver, punch out the lock knock-out on the right side of the drawer or cabinet. Assemble lock mechanism as shown. Ensure the unthreaded part of the lock and key teeth face upward.
4. Insert bolts through the top of the drawer mounting kit into the drawer or cabinet chassis and lightly secure with washers and nuts. Repeat for other side.
5. Lift entire chassis and mounting kit assembly to rest on the inside back and front. Sandwich the front Support Rail between chassis and drawer mounting kit.
6. Secure to rear channel with bolt, washer and nut. Tighten all nuts and bolts.
  - a. If stacking items, insert small bolts from above into the pre-drilled holes in bottom back of chassis and lightly secure with nut and washer.
  - b. Align second chassis' back keyhole slot with nuts and pull forward. This will help you support the drawer while securing front nuts and bolts for stacking drawers.
  - c. Give **all** nuts and bolts a final tightening.
7. Push in drawer slides on chassis and insert complete drawer into chassis.

